

INSTRUCTION MANUAL

10 range

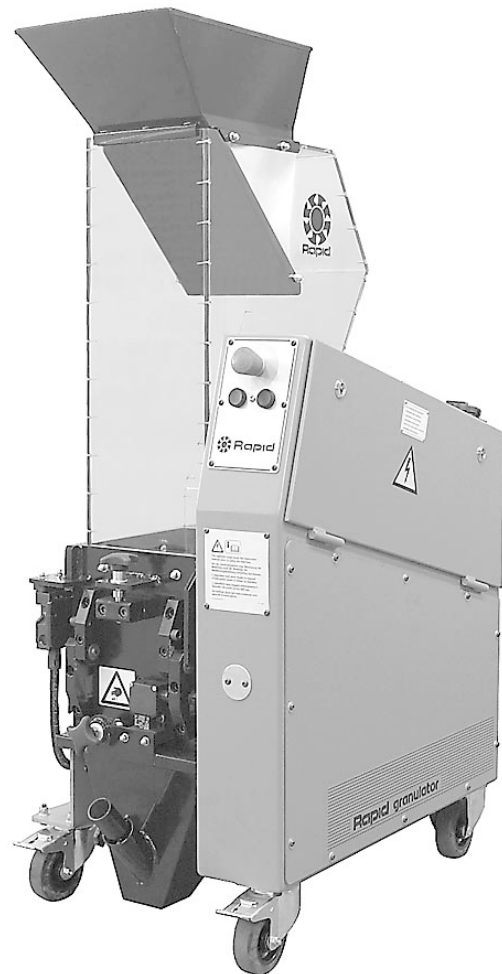

IB 11900 02 C01



1. SAFETY



RAPID granulators are designed to granulate injection moulded plastics waste.

The granulators have a safety system, which is described in chapter 4.2.



WARNING!
Risk of cutting or pinch injury!

This sign is located where there is a risk of cutting or pinch injury.



NOTE!

This sign is located where special attention is necessary.



WARNING!
Hazardous voltage!

This sign is located on the door of the electrical cabinet and any junction boxes.

Danger occurs:



- The machine contains rotating segment and feed hook. They are sharp and can cause personal damage even when they are not rotating.



- The granulator must not be used without the granule bin. The granule bin is part of the safety devices on the granulator. The granule bin must always be installed during operation.



- The granulator must not be started without the hopper funnel. If the hopper funnel is not installed, the cutter is accessible through the hopper opening and can cause personal injury.















- There is a pinch risk when the hopper and cutter housing upper part are opened and closed. Be careful.



- The electrical cabinet of the machine contains hazardous high voltage, contact can be fatal.

Note

-  • Electrical installation must only be done by a suitably qualified electrician.
-  • Before the granulator is opened for service or maintenance. Stop the granulator! Turn the main switch to the “0” position (Off) and remove the granulator’s plug from the mains socket.
-  • Never insert any part of your body into openings in the granulator, unless main switch is in the “0” position (Off) and the granulator’s plug has been pulled out from the mains socket.
-  • If the cutter has to be turned to neutral, take great care when you do this!
-  • It should not be possible to start the granulator until the hopper and granule bin are securely shut.
-  • The granulator must never be started if the electrical cabinet or transmission doors are open.
-  • The electrical cabinet and transmission doors shall always be securely installed, closed and locked when the granulator is in operation!
-  • The key for the electrical cabinet door is a safety component. The key must be kept by the person who is responsible for the granulator safety, service and maintenance.
-  • The electrical cabinet and transmission doors must never be opened when the granulator is in operation.
-  • Never remove protective gratings or pipes adjacent to the out feed or granule bin.
-  • Use protective goggles when cleaning the granulator!
-  • Use protective gloves when changing the cutting parts!

1. SAFETY



This manual applies to RAPID granulators in the 10-range. Model nos. 1022, 1034 and 1046 refer to the size of the cutter housing.



Read the manual before installation and use of the machine!



Be careful when the cutting parts are accessible. They are sharp and can cause personal injury!

This RAPID granulator is designed for granulating injection moulded plastics waste.

Granulator size and performance are chosen to suit the type of waste.

If other products or material are granulated, approval must be obtained from head office before hand for the warranty conditions to apply.

The granulator is designed to permit rapid and simple maintenance and cleaning, for both routine maintenance and material changes.

All service work must be done by trained service personnel.

This manual contains instructions for both operation and service.

Chapter 5 contains instructions directed towards service personnel.

Chapter 6 contains instructions for the accessory equipment of the machine.

Other chapters contain instructions for the operator.

Any modification and alterations to the granulator must be approved by RAPID.

This is in order to prevent personal injury and product damage, the machine warranty to apply and for product liability reasons.

If you have any questions, please contact the local RAPID distributor or the RAPID head office.

Head office:
Rapid Granulator AB
Box 9
SE-330 10 BREDARYD
Sweden.
Phone. + 46 370 865 00
Fax. + 46 370 802 51

We reserve the right to make continuous design and material changes and to amend specifications without prior notice.
RAPID GRANULATOR AB

2. SUMMARY

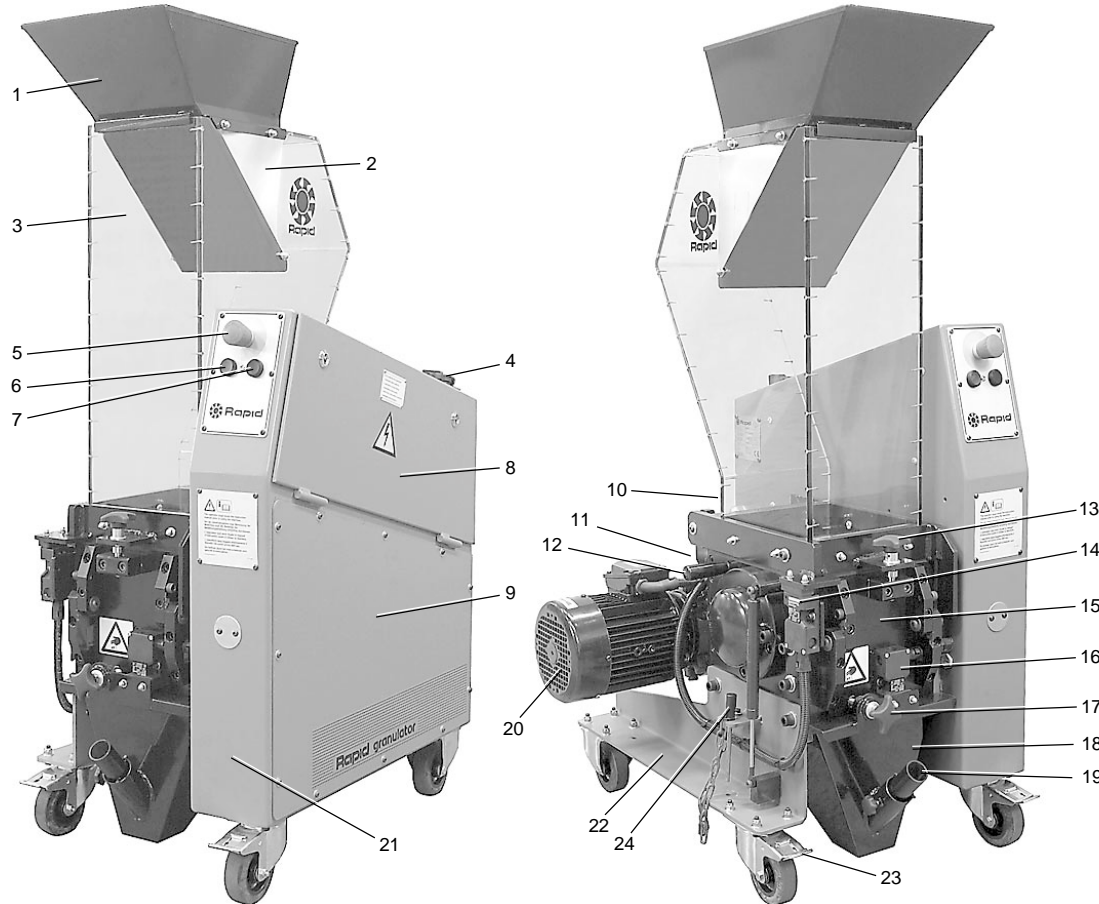

1. Hopper funnel
2. Flap in hopper opening
3. Hopper
4. Main switch
5. Emergency stop
6. Start button
7. Stop button
8. Electrical cabinet
9. Transmission
10. Support, hopper
11. Reduction gear
12. Handle, upper part cutter housing
13. Star knob, hopper
14. Safety switch, hopper
15. Cutter housing
16. Safety switch, granule bin
17. Star knob, granule bin
18. Granule bin
19. Suction pipe, out feed
20. Motor
21. Stand
22. Support, stand
23. Brake arm, wheel
24. Tool, cutter
25. Key, electrical cabinet



1. Safety	1.2	5.4 Cleaning	5.4
– Danger occurs	1.2	5.5 Changing of fixed knives, rotating segments and feed hook ..	5:5
– Note	1.3	To change the cutting parts	5:5
2. Introduction and table of contents	2.1	– Removal of fixed knives	5:5
– Introduction	2.1	– Removal of rotating segments and feed hook	5:5
– Summary	2.2	– First install the rotating segments and feed hook	5:6
– Contents	2.3	– Then install the fixed knives	5:8
3. Installation	3.1	5.6 Grinding of cutting parts	5:9
3.1 Lifting the machine during installation	3.1	– Grinding fixed knives	5:9
3.2 Installation	3.2	– Grinding rotating segments and feed hook	5:9
– Eight hours or one day after first start	3:2	5.7 Transmission	5:10
3.3 Electrical connection	3.2	– Reduction gear	5:10
– Check the direction of rotation of the granulator motor	3.2	– Check the drive belt condition	5:11
– If the direction of rotation of the granulator motor is incorrect	3.3	5.8 Lubrication	5:11
4. Operation	4.1	– Granulator	5:11
4.1 Function description	4.1	6. Options	6:1
4.2 Safety system	4.2	6.1 REV "Reversing system"	6:1
– Safety switches	4.2	– Function	6:1
– Star knobs	4.3	– Profram relay	6:1
– Emergency stop	4.3	6.2 Level monitor	6:3
– Before starting, ensure that	4.3	– Setting the paddle monitor sensitivity	6:3
– The key for the electrical cabinet door	4.3	6.3 Hours counter	6:4
4.3 Starting and stopping	4.4	7. Electricity	7:1
– Start	4.4	8. Fault finding	8:1
– Stop	4.4	– If the granulator does not start	8:1
5. Maintenance and service	5.1	– Check the granulator options	8:1
5.1 Inspection	5.1	– If the granulator does not start after normal fault finding	8:2
– Daily inspection	5.1	9. Spare parts list	9:1
– Weekly inspection	5.1	– Ordering spare parts	9:1
– Every 6 months or 4000 running hours	5.1	– Summary, modules, optional modules	9:1
– Check annually or 8000 running hours	5.1	10. Layout	10:1
5.2 Opening of hopper, granule bin and cutter housing	5.2	11. Transport and storage	11:1
– Open the hopper	5.2	11.1 General	11:1
– Open the granule bin	5.2	11.2 Transport	11:1
– Open the cutter housing	5.2	11.3 Storage	11:2
5.3 Closing of cutter housing, granule bin and hopper	5.3	12. Technical specifications, Maintenance & service schedule ..	12:1
– Close the cutter housing	5.3		
– Install the granule bin	5.3		
– Close the hopper	5.3		

Please read all of chapter 3 before installing the machine.
All instructions must be followed in sequence to avoid damage.

3.1 Lifting the machine during installation

The machine must be transported by trained personnel.
The machine is supplied packed in protective plastic foil, locked to a transport pallet with screws and PET straps.

Removing packaging and goods arrival inspection

- Check that the machine has not been damaged in transport.



NOTE! Any damage must be reported to the goods forwarding agency.

- Do not remove the packaging from the machine until it has been transported to the place where it will be installed.
- Check the dispatch note to see that the shipment is complete.

Lifting and transporting the machine to the place where it will be installed.

The machine weighs about 335 - 385 kg, including packaging.
The space needed is noted in Layout, chapter 10.
The machine can be lifted and handled by means of a fork-lift truck or a traversing crane.

With a fork-lift truck

The machine can be lifted and handled by means of a fork-lift truck

1. Set the fork width on fork-lift truck to 400 mm.
2. Remove the granule bin.
3. Drive in the fork-lift truck and make sure that the lifting forks balance the granulator, then lift the machine.

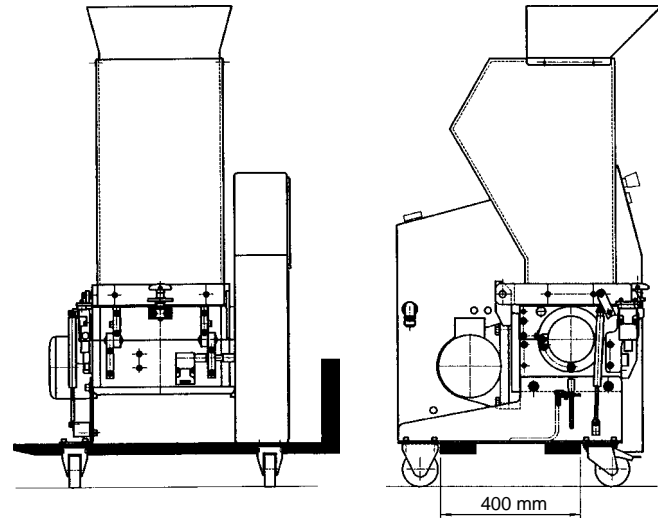

3. INSTALLATION



With traversing crane and a lifting strop

The machine can be lifted by means of a double strop and a lifting yoke.

The length of the strop should be at least 5 metre (10.0 m circumference).

1. Remove the granule bin.
2. Install the lifting strop underneath the granulator stand.
3. Then install a lifting yoke.

Use a traversing crane or a fork-lift truck and then lift the machine as shown in the illustrations.

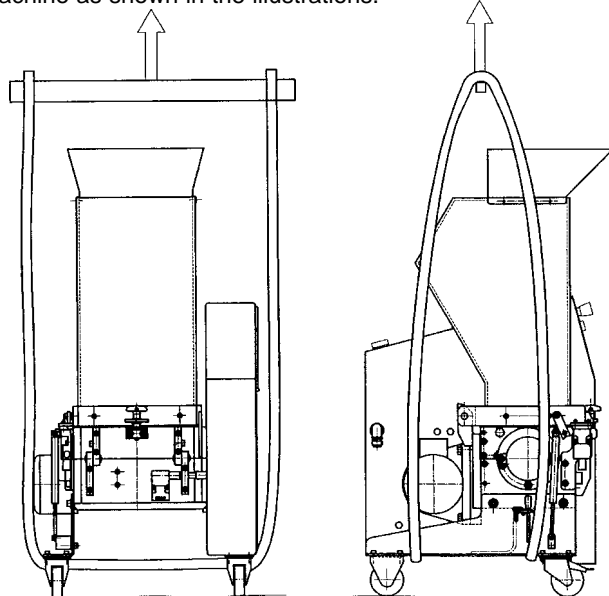

3:2

3.2 Installation

NOTE! The key for the electrical cabinet is a safety component. The key must be kept by the person who is responsible for granulator safety, service and maintenance.

- Put the granulator in place and ensure that it is horizontal and stable on the ground.
- The unpainted components of the machine are coated with rust preventer for protection before transport and delivery.

Clean the granulator from rust protection agent before it is used.

- Lock the wheels, tread the wheel brake catches down.

Eight hours or one day after first start

Check the knife clearance and tightening torque of the fixed knives retaining screws. Read chapter 5.5 in this manual.

3.3 Electrical connection

Connection to the mains must only be done by a suitably qualified electrician.

- Connect the granulator to the mains. The system voltage (Volt) and fuse size (Amp) of the machine is noted in the wiring diagram.
- Check the phase sequence of the mains with a phase sequence indicator and connect the granulator to the mains with a mains plug.

Check the direction of rotation of the granulator motor

- Check that the hopper and granule bin are securely shut. The star knobs on the hopper and the granule bin must be securely screwed in.

10-range

2001-11-02

- Check that the granulator is steady on the ground, lock the wheels, tread the wheel brake catches down.
- Connect the mains plug to the mains outlet.
- Turn the main switch to position “1” (On)
- Start the granulator, press the “Start” button.
- Check that the direction of rotation of the granulator motor coincides with the arrow on the motor housing.

Tip! Start the motor and stop it again at once.

Before the motor has had time to stop completely – carefully insert a cable tie into the rear of the motor housing and carefully feel the direction of rotation of the motor.

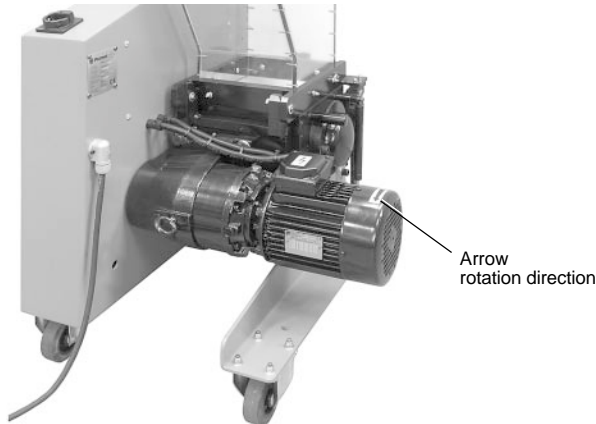

- Turn the main switch to position “0” (Off) and pull the mains plug out of the mains outlet.
- Transpose two of the incoming phases in the mains plug.

NOTE! Sign the instruction manual, chapter 12, when the installation is completed.

If the direction of rotation of the granulator motor is incorrect:

- Stop the granulator, press the “Stop” button.

3. INSTALLATION



4.1 Function description

The granulator is designed for cutting up plastics waste to granulate, for re-use.

The plastics waste must be free from metal objects and contamination before granulation.

The granulator is started and stopped with the press buttons on the control panel.

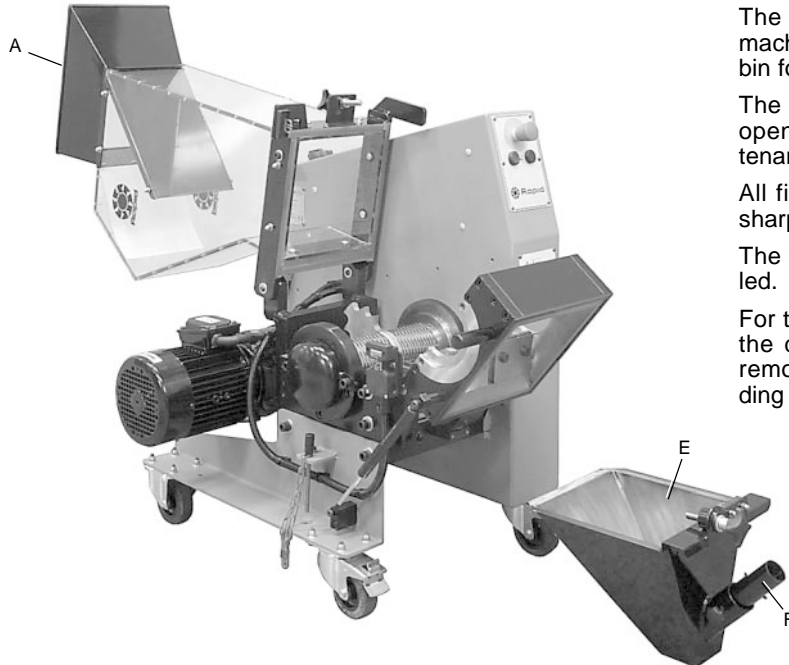

The plastics waste is put into hopper "A" and falls down into the cutter housing, where the feed hook "B" and rotating segments "C" cut the plastic into pieces, against fixed knives "D", to form granulate.

The granulate falls down to the granule bin "E", which collects the finished granulate.

The granule bin can be emptied with vacuum suction through the out feed pipe "F".

The finished granulate can be used at once in the production machinery. The granulate can also be transported to a collection bin for later use.

The granule bin can be easily removed and the hopper can be opened to give improved access during cleaning and maintenance.

All fixed knives and cutting parts in the granulator can be re-sharpened.

The fixed knives can easily be removed, grinded and re-installed.

For to grind rotating segments and feed hook recommends that the details sends to RAPID. It requires skill & knowledge to remove and install the rotating segments and feed hook. Grinding is then done exactly by means of a special grinding jig.

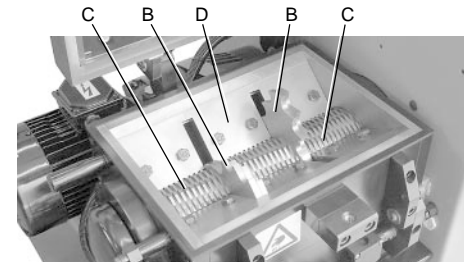

4. OPERATION

4.2 Safety system

The granulator has a safety system which is intended to prevent access to dangerous components during operation.

Feed hook and rotating segments rotate with high power inside the granulator. For this reason, the granulator is provided with safety switches and a emergency stop to prevent personal injury.

The hopper, hopper funnel and granule bin are components which are included in the granulator safety system.

NOTE! These components must always be securely fastened before the granulator can be started.

The safety system must not be changed or modified under any circumstances.

If the safety system is changed or modified in any way, it can be dangerous to use and could cause serious personal injury.

All maintenance and service which relates to the safety systems of the granulator must be carried out with personnel who have the necessary training and knowledge.

If the safety system is changed or modified in any way, RAPID's product responsibility under the Machinery Directive ceases to apply.

No component in the safety system may be replaced by anything other than spare parts provided by RAPID.

4:2

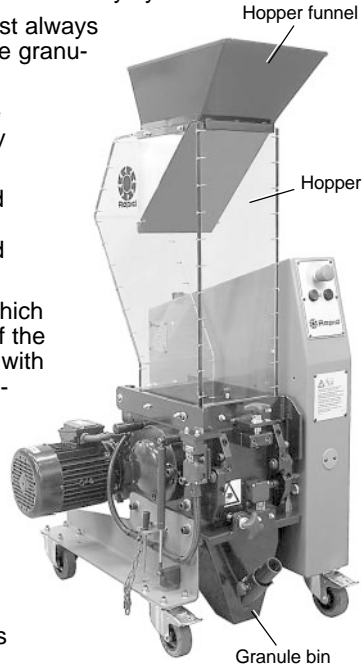

10-range

Safety switches

The safety switches consist of a star knob with long screw and a position switch with circuit breaking key.

The safety switches cut the current so that the granulator can not be started when any hazardous section of the granulator is accessible.

This granulator has 2 safety switches:

- 1 by the hopper (between the hopper and the cutter housing).
- 1 by the granule bin (between the granule bin and the cutter housing).

When the hopper and granule bin have been opened, it should not be possible to start the granulator.

When the star knob on the hopper or granule bin has been opened, the circuit breaking key position is changed. The position switch then cuts the current and the granulator stops.

The screw on the star knob is long. It should take such a long time to undo a star knob that the granulator has time to stop before any hazardous component of the granulator becomes accessible.

NOTE! The granulator must never be routinely stopped by using the safety switches. Stop the granulator with the stop button. Turn the main switch in position "0" (Off) and pull the mains plug out of the mains outlet before doing any cleaning, maintenance or service.

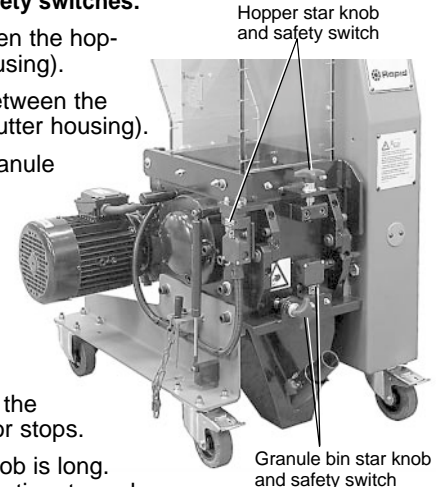

2001-11-02

Star knobs

The star knobs on the hopper and granule bin are important components in the granulator safety systems.

The length of the screw is selected so as to give the granulator time to stop before the star knob is fully undone and the knives become accessible.

On this granulator, the star knobs should have screws which are 40 mm long.

When safety components are changed, only spare parts supplied by RAPID may be used.

Star knobs with worn threads may only be replaced by new ones supplied by RAPID. Please refer to chapter 9 for spare parts.

Note! When a star knob is installed, there should be a clearance between flange, knob and bracket.

Checking the safety switches

NOTE! Be careful!

1. Screw in the star knobs on the hopper and granule bin firmly until they bottom.
2. Connect the mains plug to the mains outlet.
3. Turn the main switch to position “1” (On).
4. Start the granulator, press the start button.
5. Undo, unscrew the star knob on the hopper.

Check that the granulator stops (the safety switch cut the current) before the star knob has been rotated 4 turns.

Star knob



6. Undo, unscrew the star knob on the granule bin.

Check that the granulator stops (the safety switch cut the current) before the star knob has been rotated 4 turns.

If the granulator does not stop before the star knob has been rotated 4 turns (the safety switch does not cut the current).

Stop the granulator with the stop button, put the main switch in position “0” (Off) and pull the mains plug out of the mains outlet.

Contact RAPID – there is a severe risk of personal injury.

Emergency stop

This is the red button on the granulator control panel.

Press the button to stop the granulator quickly.

Re-set by turning the knob in the direction of the arrow (anti-clockwise).

The granulator might be equipped with more than one emergency stop.

Before starting, ensure that

- The hopper and granule bin must be securely closed. The star knobs on the hopper and granule bin must be fully screwed in.
- The electrical cabinet and transmission doors shall always be securely installed, closed and locked!

Check the safety systems of the granulator regularly.

The key for the electrical cabinet door

NOTE! The key for the electrical cabinet is a safety component. The key must be kept by the person who is responsible for granulator safety, service and maintenance.

4. OPERATION



4.3 Starting and stopping

Starting and stopping is controlled from the control panel.

Start

Before the granulator is started, ensure that:

- The hopper and granule bin must be securely closed. The star knobs on the hopper and granule bin must be fully screwed in.
- The electrical cabinet and transmission doors shall always be securely installed, closed and locked!
- The granulator must be securely installed beside the injection moulding machine, with the wheels locked.

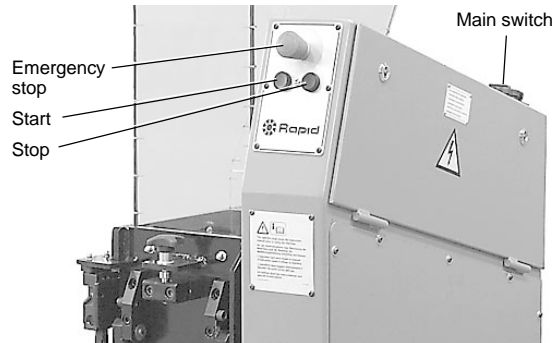

Start the granulator

1. Connect the mains plug to the mains outlet.
2. Turn the main switch to position "1" (On).
3. Check that the emergency stop button is not depressed.
4. Press the start button.

Stop

Stop the granulator

1. Stop the granulator with the stop button.
2. Turn the main switch to position "0" (Off).
3. Press the emergency stop button.
4. Pull the mains plug out of the mains outlet.

5.1 Inspection

There must not be any material residue left in the granulator during inspection.



NOTE! Checks every 6 months and annually must be done by trained personnel, to avoid personal injury and machinery damage.

Sign in this manual, chapter 12, when the check is completed.

Daily inspection

- **Emergency stop.** Check the emergency stop function. Start the granulator and then do an emergency stop with the emergency stop button.

Re-set the emergency stop, turn the button in the direction of the arrow (anti-clockwise).

- **Flap.** Check that the flap in the hopper opening is intact.

A damaged flap can allow material to be thrown back through the hopper opening. Change a damaged flap at once.

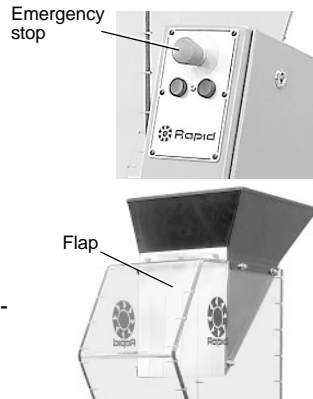

Weekly inspection

- **Cables.** Check all cables on the machine.

There must never be any damaged or loose cables. Call a competent electrician to get it fixed.

- **Safety switch.** Check the function of the safety system. Read chapter 4.2 "Safety system" in this manual.

This granulator has 2 safety switches.

- 1 by the hopper (between the hopper and the cutter housing)
- 1 by the granule bin (between the granule bin and the cutter housing).



NOTE! Components and parts in the safety of the machine must only be replaced by spare parts supplied by RAPID.

Every 6 months or 4000 running hours

- Check the wear on fixed knives, rotating segments and feed hook.

Grind the fixed knives, rotating segments and feed hook if they are worn, read chapter 5.6.

- Check the tightening torque of the fixed knives retaining screws, tightening torque 85 Nm.

Check annually or 8000 running hours

- Check the drive belt condition.
- Check the oil level in reduction gear, read chapter 5.7.
- Check the sealings to cutter housing bearings.

Change the sealings as necessary.

5. MAINTENANCE AND SERVICE

5.2 Opening of hopper, granule bin and cutter housing

Stop the granulator with the stop button.

Turn the main switch to position "0" (Off).

Press the emergency stop button.

Pull the mains plug out of the mains outlet.



Be careful when the hopper and granule bin are open!



The cutting parts are then accessible. They are sharp and can cause personal injury!



Pinch risk in the following tasks, be careful!

Undo the wheel brakes and move the granulator away.

NOTE! Make sure that the granulator has stopped before it is moved.

Open the hopper

- Undo the star knob "G" to the hopper "A".

The safety switch between hopper and cutter housing ensures that the granulator can not be started, when the hopper has been opened.

- Fold the hopper backwards.

The hopper will stop against a stop heel in open position.

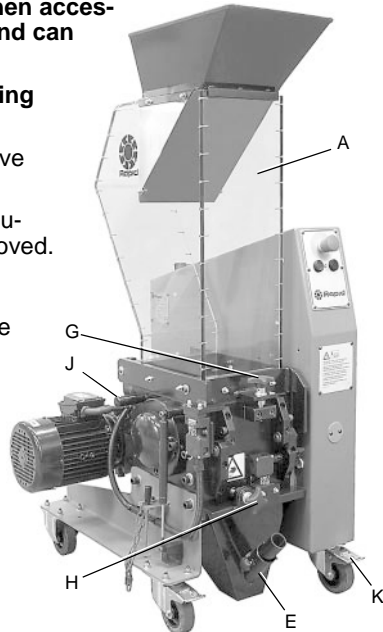

10-range

Open the granule bin

- Undo the star knob "H" on the granule bin "E".
- Pull the handle and draw the granule bin "E" straight out.

The safety switch between granule bin and cutter housing ensures that the granulator can not be started, when the granule bin has been opened.

Open the cutter housing

- Grasp the handle "J" and then lift the upper part of the cutter housing upwards and forwards.

NOTE! Be careful when the hopper, granule bin and cutter housing are opened! The cutting parts are then accessible, they are sharp and can cause personal injury!

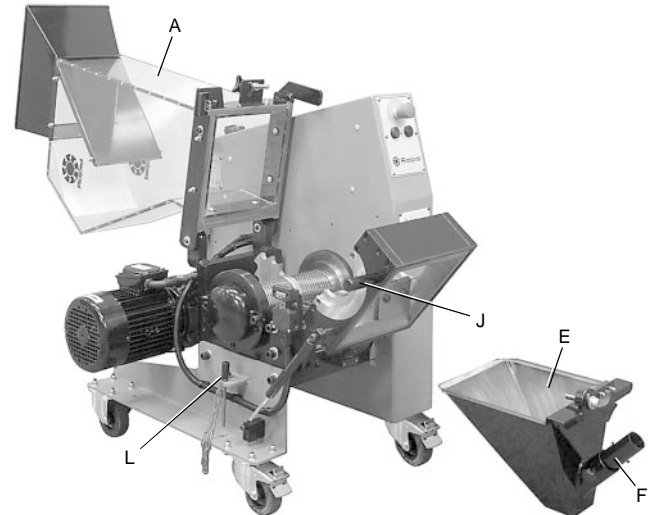

2000-11-02

5.3 Closing of cutter housing, granule bin and hopper



NOTE! Before closing, make sure that the mating surfaces are clean!

Close the cutter housing

- Grasp the handle "J" and then lift the upper part of the cutter housing backwards and down.

Install the granule bin

- Install the granule bin "E".
Fit the granule bin into the grooves on the cutter housing and then slide the granule bin in until it stops.
- Fasten the granule bin, screw in the star knob "H" firmly until it bottoms.



NOTE! The granulator can not be started unless the granule bin is securely closed. The star knob must be screwed in firmly until it bottoms.

Close the hopper

Check and make sure that no granulate lies on the mating surfaces.

- Fold the hopper "A" upwards and forwards.
- Fasten the hopper, screw in the star knob "G" firmly until it bottoms and the hopper fits neatly against the cutter housing.



NOTE! The granulator can not be started unless the hopper is securely closed. The star knob must be screwed in firmly until it bottoms.

- Check that the granulator stands firmly. Lock the wheels, press the wheel brake arms "K" down.

- Connect the mains plug to the mains outlet.
- Turn the main switch to position "1" (On).
- Check that the emergency stop button is not depressed.
- Start the granulator, press the start button.

5. MAINTENANCE AND SERVICE



5.4 Cleaning

Clean the granulator at colour changes or monthly.

1. Check that the hopper is empty, then stop the granulator with the stop button.
2. Open the hopper, granule bin and cutter housing, read chapter 5.2



Be careful when the hopper, granule bin and cutter housing has been opened! The knives are then accessible. They are sharp and can cause personal injury!

3. Use a vacuum cleaner during cleaning.
4. Clean the granule bin.
5. Clean the inside of the cutter housing.

Clean properly under the fixed knives.

The cutter can be rotated manually, use the tool "L".

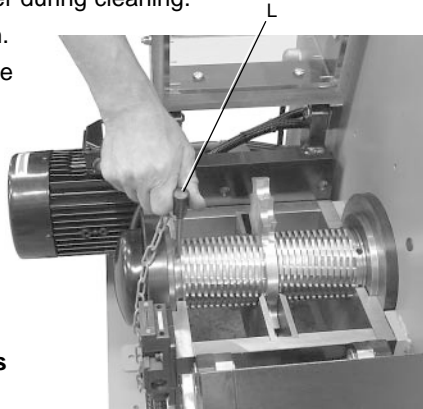

NOTE! When the cutter is rotated manually, do this with great care.



The knives are sharp and can cause personal injury.

6. Clean the polycarbonate hopper use only a soap water solution.



NOTE! A normal washing detergent solution can damage and explode the polycarbonate hopper.

7. Close the cutter housing, granule bin and hopper, read chapter 5.3
8. Clean the granulator outside, use vacuum cleaner.

5.5 Changing of fixed knives, rotating segments and feed hook

Changing the cutting parts of granulator must be done by trained personnel, to avoid personal injury and machinery damage.



NOTE! Be careful when handling the cutting parts of granulator. They are sharp and can cause personal injury!



When the cutter is rotated manually, do this with great care.

To change cutting parts:

1. Check that the hopper is empty, then stop the granulator with the stop button.
2. Remove the granule bin and open the hopper, read chapter 5.2



Be careful when the hopper, granule bin and cutter housing has been opened! The cutting parts of granulator are then accessible, they are sharp and can cause personal injury!

Removal of fixed knives

1. Undo and remove the screws "M" and washers "N".
2. Remove the fixed knives "D".

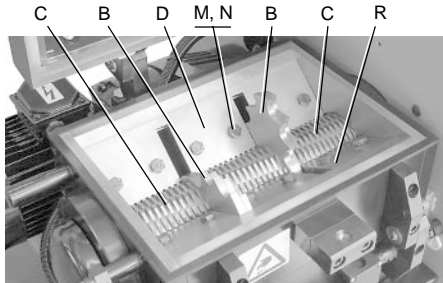

Removal of rotating segments and feed hook

It requires skill & knowledge to remove and install the rotating segments "C" and feed hook "B".

1. Undo and remove the covering plate to transmission.

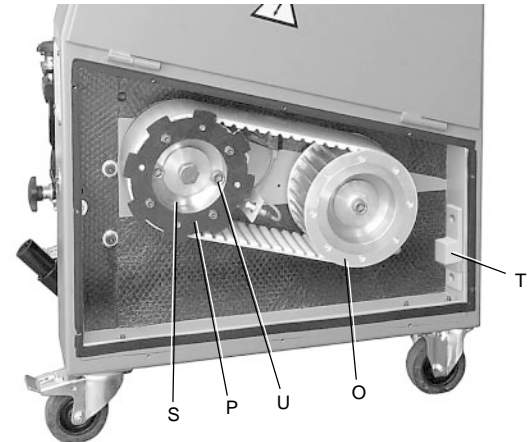

2. Undo and remove the support ring "O" from motor pulley.
3. Granulators with "REV"-system, undo and remove the indication ring "P" from cutter pulley.
4. Lock the feed hook against the scrapers "R" or against cutter housing with a piece of wood.

Undo and remove screw and washer to cutter shaft in the center of cutter pulley.

5. MAINTENANCE AND SERVICE



5. Remove the cutter pulley "S", use the remover "T".
Undo and remove the 2 socket cap screws "U" in the center of cutter pulley.
Install the remover using the socket cap screws "U" and tighten, to release the cutter pulley.
6. Undo the 4 hex head screws "V" which hold reduction gear and motor against cutter housing.
Undo the screws 3 turns.
NOTE! Don't remove the screws.
7. Remove the drive belt.
Turn motor and reduction gear backwards to decrease the drive belt tension, then the drive belt can be removed.

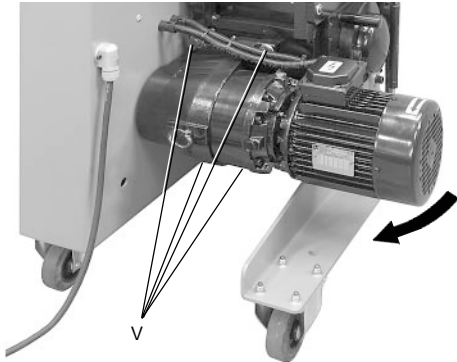

8. Undo and remove the bearing cover on cutter housing free wheeling side.

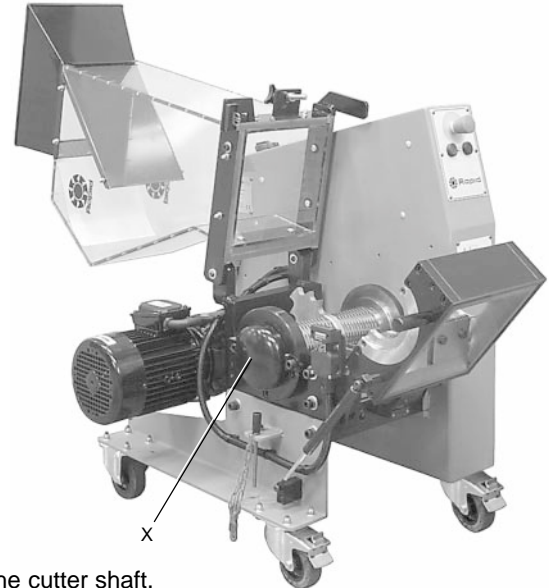

9. Undo the cutter shaft.

NOTE! The cutter shaft don't need to be totally removed to remove rotating segments and feed hook.

Strike carefully the key-joint shaft center with a bronze punch from transmission side.

Be careful, hold each rotating segment and feed hook when you remove the cutter shaft.

NOTE! Never let a segment or a feed hook fall down out of control.

Hardened steel segment and feed hook are brittle and can crack if they fall down out of control.

First install the rotating segments and feed hook

It requires skill & knowledge to install the rotating segments and feed hook.

For to install rotating segments and feed hook recommends that the granulator sends to RAPID.

1. Clean properly the inside of cutter housing, scrapers and knife position for the fixed knives.
2. Grease the cutter shaft properly, use graphite grease.
3. Install rotating segments "C" and feed hook "B" on the cutter shaft.

Note! The granulator models 1034 and 1046 with more than one feed hook. The feed hooks should be installed with displaced positions.

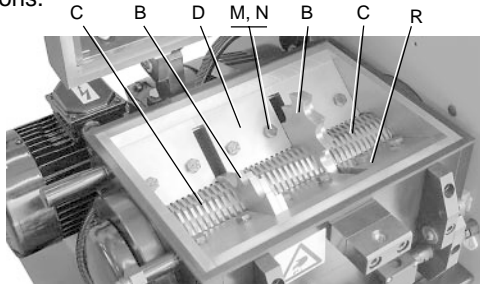

Strike carefully the key-joint shaft center, use a plastic- or rubber mallet from the cutter housing free wheeling side.

At the same time install rotating segments and feed hook. Make sure that the key fits into segments and feed hook.

4. Install the drive belt.

Turn motor and reduction gear backwards so that the drive belt can be installed without tension.

5. Fasten reduction gear against the cutter housing with the 4 hex head screws "V", tightening torque 220 Nm.
6. Install the support ring "O" on motor pulley.

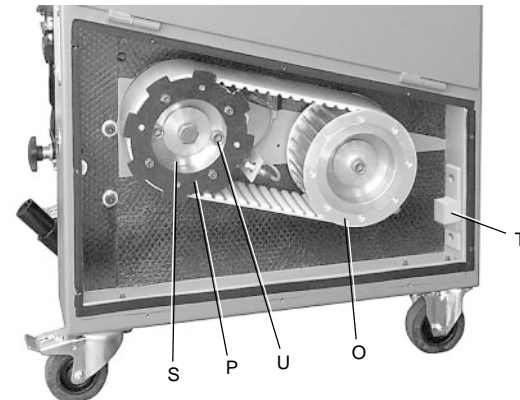
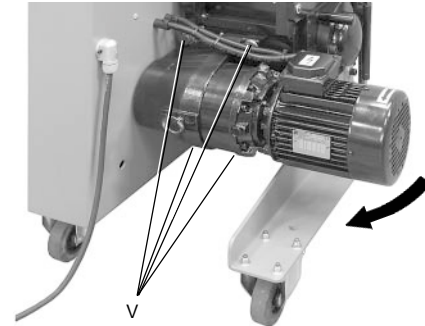

7. Install the cutter pulley "S".

5. MAINTENANCE AND SERVICE



8. Fasten the cutter pulley.

Lock the feed hook against the cutter housing with a piece of wood. Fit screw and washer to cutter shaft in the center of cutter pulley.

Fasten the cutter pulley with tightening torque 220 Nm.

9. Fit the 2 socket cap screws "U" from the remover in cutter pulley center.

10. Granulators with "REV"-system, install the indication ring "P" on cutter pulley.

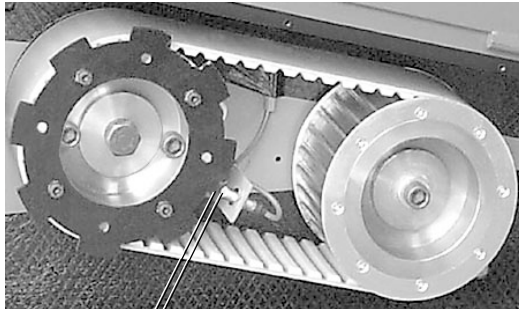

Check and adjust the clearance between indication ring and inductive sensor. Clearance 1,0 mm.

11. Remove the wooden piece from cutter housing.

12. Replace the remover.

13. Install the bearing cover "X" on cutter housing free wheeling side.

14. Install and fasten the covering plate to transmission.

5:8

Then install the fixed knives

15. The fixed knives "D" should be properly cleaned.

16. Close the upper part of cutter housing.

17. Check that the knife position for fixed knives is properly cleaned.

18. Then install the fixed knives.

Install the screws and washers to fixed knives and fasten so that the screws lightly supports the knives.

19. Rotate the cutter a few turns and carefully check that rotating segments and feed hook can pass the fixed knives freely.

20. Set the knife clearance, adjust the fixed knife positions against rotating segments.

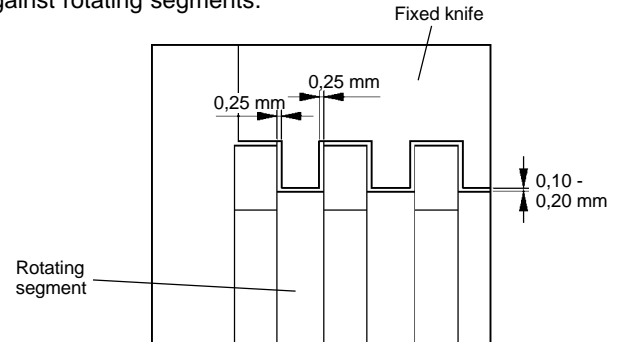

21. Tighten the screws "M" to the fixed knives with an alternated increased torque to 85 Nm.

22. Close hopper and install the granule bin.

NOTE! Sign in the service schedule, chapter 12, when changing of fixed knives, rotating segments and feed hook is completed.

10-range

2000-11-02

5.6 Grinding of cutting parts

Note! The instruction for grinding cutting parts refers to 3 different parts.

Grinding of: – fixed knives
– rotating segments
– feed hook



Be careful when you handle cutting parts!



Cutting parts are sharp and can cause personal injury.



NOTE! Hardened steel cutting parts are brittle and can crack if they are dropped or handled carelessly.

Cool the cutting parts during grinding

Cool the cutting parts during grinding, grind slowly and make sure that no heat is generated.

Grinding fixed knives

Cutting angle 90°.

The fixed knives can be turned over and two sides can be grinded.

This means that the knives can be turned over and two cutting sides can be used before they have to be re-ground.

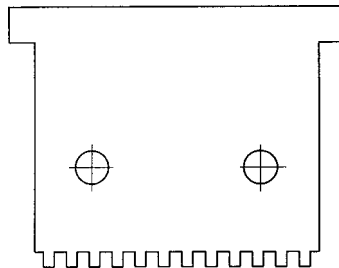

During grinding use a surface grinder with magnetic table.

Minimum measure is 10 mm for fixed knives.

After that, the knives are used up and must be replaced by new ones.

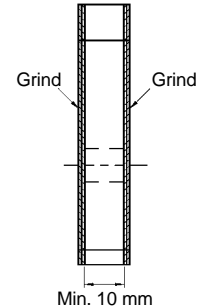

Grinding rotating segments and feed hook

It requires skill & knowledge to remove, grind and install the rotating segments and feed hook.

For to grind rotating segments and feed hook recommends that the details sends to RAPID.

Rotating segment

The edges are angled on rotating segments.

The segment edges should be grinded with diameter 6 mm.

NOTE! The minimum measure is 4,5 mm on rotating segment heads

After that, the rotating segments are used up and must be replaced by new ones.

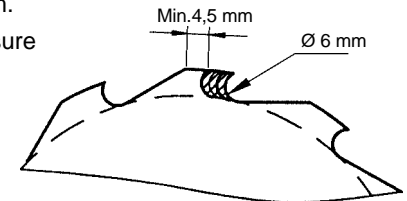

5. MAINTENANCE AND SERVICE



Rotating feed hook

The rotating feed hook direction is reversible and two directions can be grinded.

The rotating feed hook should be grinded with a tripple and double contour profile.

It is important to keep the double tripple profile. It is also important to keep the specified angles and measures between 1:st and 2:nd profile.

The profile edges on the feed hook should be sharp and with 90° cutting angle.

The diameter in rotating feed hook contour base should be grinded to diameter 21 mm.

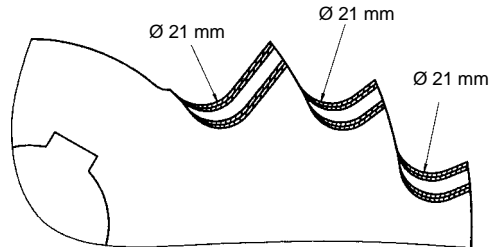

5.7 Transmission

The machine is driven by a ribbed belt.

Check annually or each 8000 running hours, the drive belt condition and the oil level in reduction gear.

- Check that the hopper is empty, then stop the granulator with the stop button.
- Turn the main switch to position "0" (Off).
- Press the emergency stop button.
- Pull the mains plug out of the mains outlet.

Reduction gear

The reduction gear is filled with mineral oil on delivery:

AGIP ROTRA MT 80W90 (ISO VG 220).

In normal circumstances, the oil does not need to be changed.

 **NOTE!** Never fill above level indicator.

 **NOTE!** Mineral oil and syntetic oil should never be mixed.

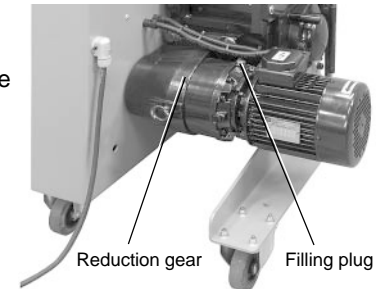
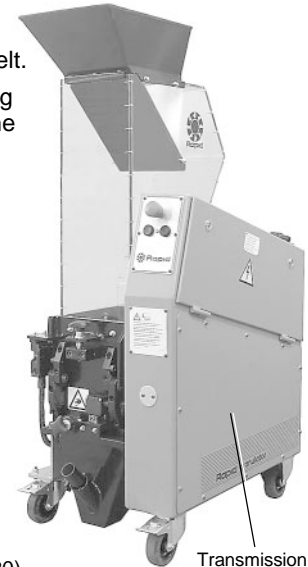

Check the drive belt condition

- Undo and remove the covering plate to transmission.

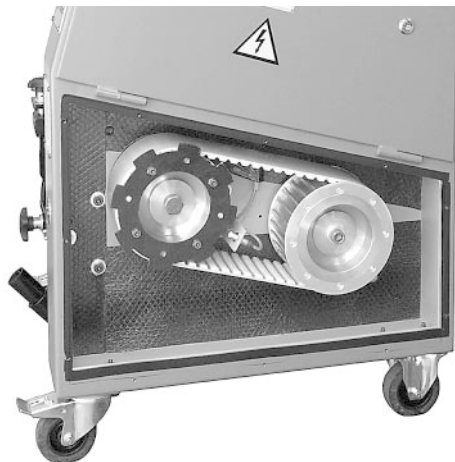

- Rotate the pulley with the drive belt a several turns.



WARNING! Pinch risk between pulley and drive belt.

Check that the drive belt is intact and does not have any cracks. Change the belt as necessary

For to change the drive belt, read chapter 5.5 "Changing of fixed knives, rotating segment and feed hook" which contains instructions to remove and install the drive belt.

5.8 Lubrication

Granulator

All bearings in the granulator are lubricated for life and can not be lubricated later on.

6.1 REV "Reversing-system"

For to easily avoid stop and overloading of the granulator, the "Reversing -system" is a practical option.

The REV-system normally reverse the cutter during continuously operation each 6 minutes to avoid stop and overloading. The cutter stops, reverse half a turn, stops and re-start forwards automaticly.

Normal settings

The program relay settings on delivery :

After 6 minutes operation stops the cutter, reverse 1,2 seconds and re-start forwards.

At overloading

When the cutter is overloaded, blocked and stops, the REV-system sense the overloading.

The REV-system reverse the cutter which change direction and back half a turn, stops and re-start forwards automaticly.

After the 3:rd consecutively reversing, stops the granulator.

NOTE! The REV-system don't protect the granulator, if metal parts falls down into the cutter housing.

Overload settings

The relay is set so that:

After 1 seconds cutter stop, reverse the cutter.

The cutter reverse 1,2 seconds and re-start forwards (1,5 sec stop during demagnetizing).

After the 3:rd consecutively reversing, stops the granulator.

Reset the granulator after 3:rd stop

1. Stop the granulator with the stop button.

2. Open the hopper, granule bin and cutter housing, read chapter 5.2.
3. Clean the granulator, read chapter 5.4.
4. Re-start the granulator.

Function

A program relay in electrical cabinet, together with an inductive sensor in the transmission controls the REV-function.

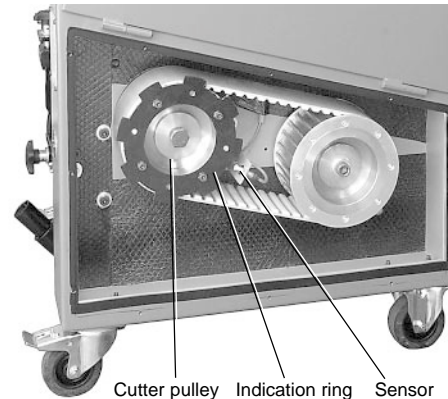

Program relay

The operation time of the granulator, the time before the auto-reversing, can be set in the program relay. The reversing time can not be set.

The time for sensing overload-stop and following reversing sequence can not be adjusted.

6. OPTIONS



Programming the relay

NOTE! All electrical maintenance and service must be done by a competent electrician.

The dorr to electrical cabinet should always be securely closed and locked when the granulator is in operation.

The key is kept by the person who is responsible for granulator safety, service and maintenance.

Stop the granulator.

NOTE! Never stop the granulator before all material in the hopper and cutter housing are completely granulated.

1. Stop the granulator with the stop button.
2. Press the emergency stop button.
3. Turn the main switch to position "1" (On).

Open the electrical cabinet.

Show parameters

- Press "ESC" and "OK" at same time.

Select "Set Param" with

- Press "OK"

Set parameters

- Press "OK" for come to
T = "0"6:00

- To move marking use or
- To change value use or

```
REV SYSTEM
06:00m
01:31m
000000
```

Relay normal position

Operation time before stop and reversing
Actual operation time

```
Set Clock
>Set Param
```

```
B28:T
T = 06:00m
Ta= 00:00m
```

Parameter
Operation time before stop and reversing
Actual operation time

```
B01:T
T = 00:00m
Ta=01:00m
```

- To confirm the settings press "OK"
- To back menu press "ESC"
- Press "ESC"
- Press

```
I:123456
Mo 09:00
Q:1234 RUN
```

At overloading

When the cutter is overloaded, blocked and stops, the REV-system sense the overloading.

After the 3:rd time reversing direction the granulator stops and the relay indicate.

```
REV STOP
000003
```

6.2 Level monitor



The granule bin can be equipped with an optional level monitor, designed as a paddle monitor.

The paddle monitor senses the granulate level in the granule bin and stops the granulator, or the granulator feed device conveyor etc. when the level of granulate in the granule bin is too high.

The paddle monitor has three standard settings when manufactured:

1. The paddle monitor stops the granulator.
2. The paddle monitor stops the granulator and lights up the sirlamp/microlamp.
3. The paddle monitor lights up the sirlamp/microlamp.

Setting the paddle monitor sensitivity

Paddle monitor sensitivity is adjustable

- Open, unscrew the housing covering above the paddle monitor microswitches.
- Adjust the position of the torsion spring.

Use needle nose pliers to change the torsion spring position.

The normal setting of the torsion spring is in the 2:nd hole from the left.

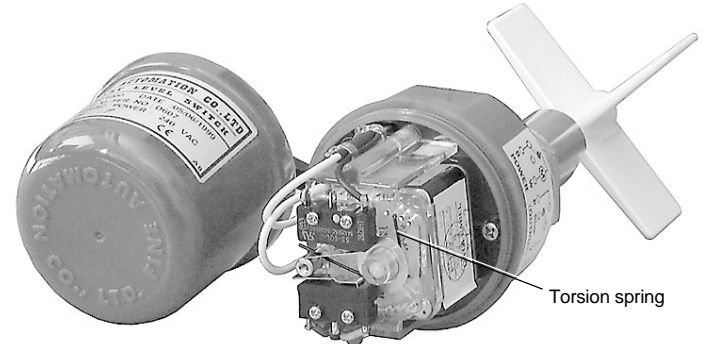
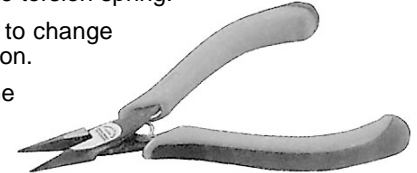

Reducing paddle monitor sensitivity

(The paddle monitor cuts the current slower)

- Move the torsion spring to the left.

Increasing paddle monitor sensitivity

(The paddle monitor cuts the current faster)

- Move the torsion spring to the right.

6. OPTIONS

6.3 Hours counter

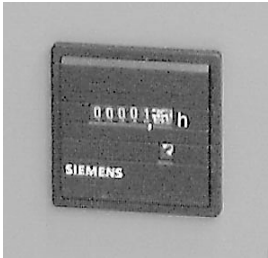

The hours counter only counts the time that the granulator cutter is moving.

The hours counter does not have a re-set facility.

Never change or modify the basic electrical settings of the granulator, without first obtaining permission from the RAPID Head Office.

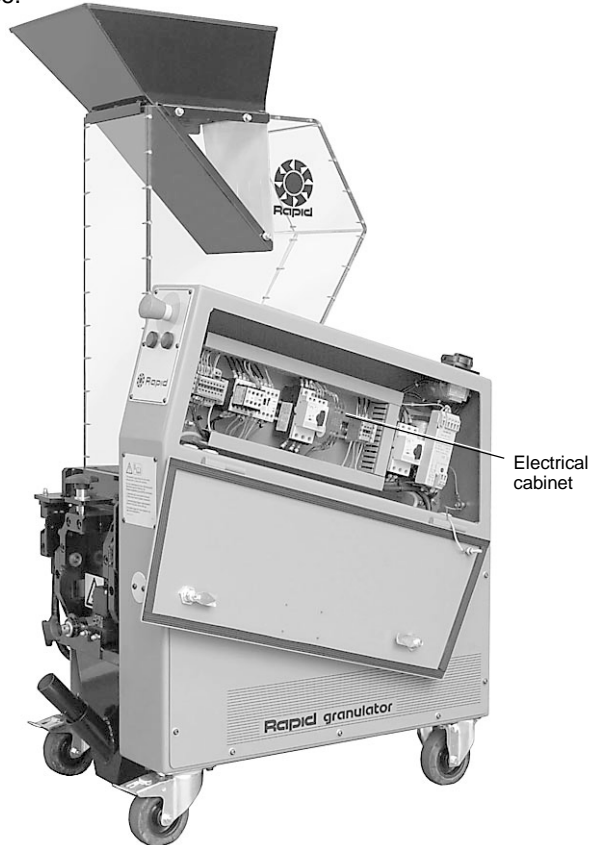

If the granulator settings are changed, the machine can be seriously damaged.

All Warranties and Rapid's Product Liability will be void, if the basic settings of the granulator are changed.

All maintenance and service work must be done by trained and competent personnel!

Electrical installation must only be done by a competent electrician!



The granulator must never be started if the electrical cabinet door is open.



The electrical cabinet door shall always be securely installed, closed and locked when the granulator is in operation!



The key for the electrical cabinet door is a safety component. The key must be kept by the person who is responsible for granulator safety, service and maintenance.



The electrical cabinet door must never be opened when the granulator is in operation.

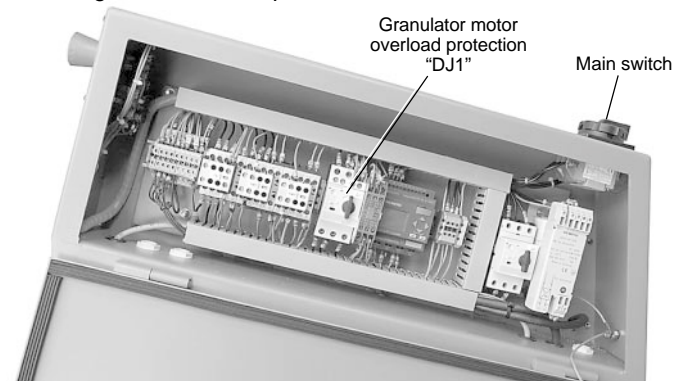

8.1 Fault finding

If the granulator does not start

- Check whether the granulator emergency stop has been pressed.
Reset, turn the knob in the direction of the arrow (anti-clockwise).
- Check that the granulator mains plug is connected to the mains
- Check that the main switch is in position "1" (On).
- Check that the star knobs on the hopper and granule bin are properly screwed all the way in.

It is not possible to start the granulator, if the star knobs the hopper and granule bin are not properly screwed all the way in. The safety switches then cut the current.

- Check the motor protection switch for the granulator motor.

The granulator has an motor protection switch "DJ1" in the electrical cabinet which trips if you block or overload the granulator.

If the motor protection switch has switched "Off", the switch will be in position "0".

Reset - turn the switch button to position "1".

Empty and clean the granulator before re-starting.

NOTE! Put the main switch in position "0" (Off). Pull the granulator mains plug out of the electrical outlet before cleaning of the granulator.

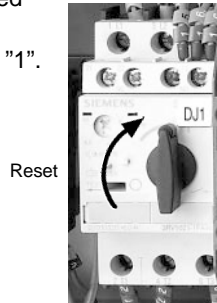

Check the granulator options

REV-system

At overloading or stop, the cutter reverse direction. After 3 time reverse directions the granulator stops.

Reset the granulator:

- Stop the granulator with the stop button.
- Clean the granulator, read chapter 5.4.
- Re-start the granulator.

REV-system don't reverse the cutter and the motor protection switch for the granulator motor trips.

- Stop the granulator with the stop button.
- Undo and remove the covering plate to transmission.

Check and adjust the clearance between indication ring and inductive sensor to REV-system. Clearance 1,0 mm.

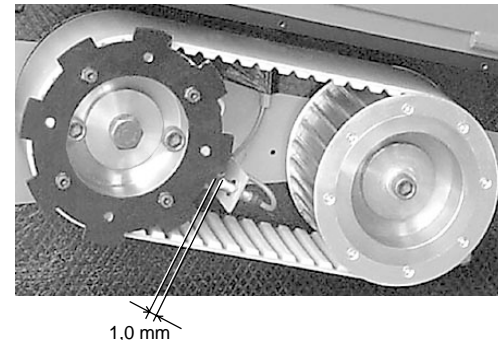

The clearance between indication ring and inductive sensor should be max. 1,0 mm.

8. FAULT FINDING



Paddle monitor

The paddle on the paddle monitor should rotate during operation.

- If the paddle monitor paddle does not rotate:
Check that the paddle monitor plug is correctly located in its socket.
- If the paddle monitor stops the granulator and the warning-lamp light is lit too early or not at all.
Adjust paddle monitor sensitivity, please refer to chapter 6.2 "Setting paddle monitor sensitivity".
- The paddle monitor stops the granulator when the granulate level in the granule bin is too high.
Empty the granule bin and re-start the granulator.

If the granulator does not start after normal fault finding.

Put the main switch in position "0" (Off).

Press the emergency stop button.

Pull the granulator mains plug out of the electrical outlet.

Contact the person responsible for service and maintenance.

NOTE! All electrical maintenance must be done by a competent electrician.

Ordering spare parts

Only use spare parts supplied by RAPID to replace machinery components.

The order must be placed with the representative in the country where the machinery was purchased.

Please include in your order:

- Designation from the identification plate on the machine.
- Serial number from the identification plate on the machine.
- Part in this spare parts list
- Quantity in this spare parts list

Summary, modules, optional modules

The granulator is sub-divided into the following modules: Page

9.1	Cutter housing	9:2
9.2	Fixed knives and cutting parts	9:3
9.3	Hopper, flaps, feed components	9:4
9.4	Transmission	9:5
9.5	Granule bin	9:6
9.6	Stand	9:7

Option modules

9.7	Paddle monitor	9:8
-----	----------------------	-----

9. SPARE PARTS LIST



9.1 Cutter housing

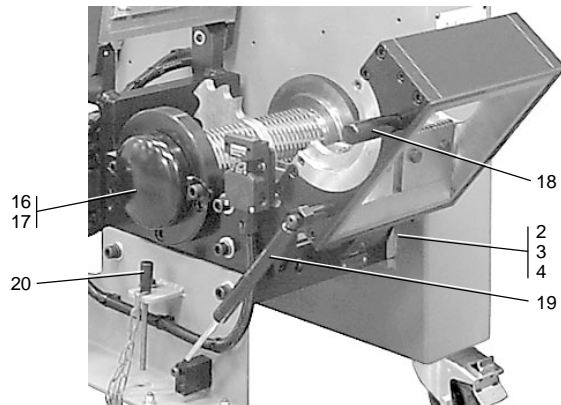
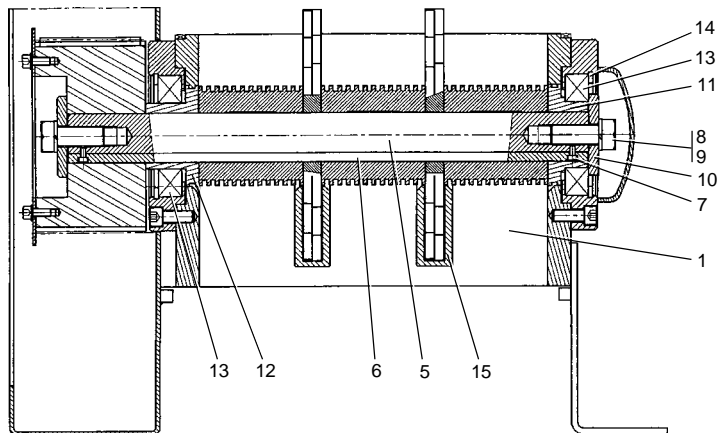

Pos	Qty.	Art. no.	Description	Note.	
1	1	-	Cutter housing 1022		
	-	1	Cutter housing 1034	1034	
	-	-	Cutter housing 1046	1046	
	-	-	Cutter housing	1022	
	-	-	- " -	1034	
	-	-	- " -	1046	
2	2	2	3	Shaft, cutter housing	
3	4	4	6	Socket cap screw, shaft, cutter housing	
4	4	4	6	Washer, shaft, cutter housing	
5	1	alt	-	Cutter shaft 0,75 kW	
	alt	1	1	Cutter shaft 1,80 kW	
6	1	alt	-	Key, cutter shaft 0,75 kW	
	alt	1	1	Key, cutter shaft 1,80 kW	
7	2	2	2	Socket cap screw, key, cutter shaft	
8	1	1	1	Screw	
9	1	1	1	Spring washer	
10	1	1	1	Washer	
11	1	1	1	Flange, free wheeling side	
12	1	1	1	Flange, driving side	
13	2	2	2	Ball bearing	6213-2RS1
14	2	2	2	Locking ring	
15	1	2	3	Guide, rotating feed hook	
16	1	1	1	Cover	
17	2	2	2	Socket cap screw	
18	1	1	1	9-92993 Handle	
19	1	-	9-92994 Gas spring	1022	
	-	1	9-92995 - " -	1034	
	-	1	9-92996 - " -	1046	
20	1	1	1	9-92997 Tool with chain, cutter	

9.2 Fixed knives and cutting parts

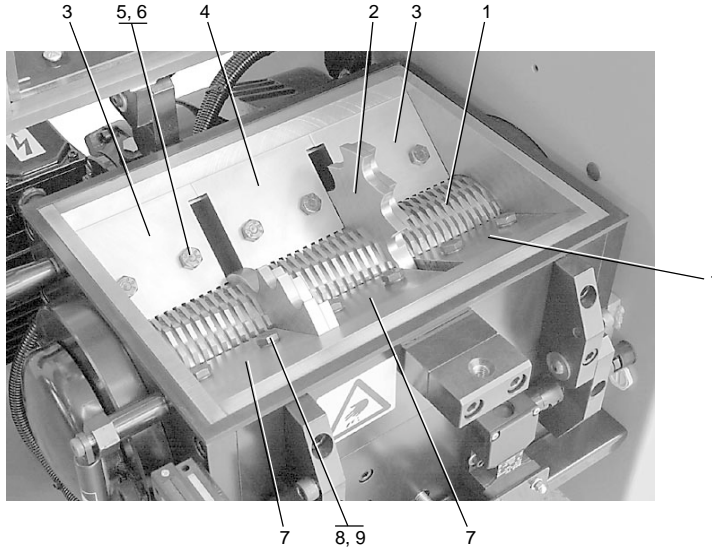

Pos	Qty.	Art. no.	Description	Note.	
			Granulator 1022		
			Granulator 1034		
			Granulator 1046		
1	2	3	4 9-92998	Rotating segment	
2	1	2	3 9-92999	Rotating feed hook	
3	2	2	2 9-93000	Fixed knife, side	
4	-	1	2 9-93001	Fixed knife, center	
5	4	6	8	Hex head screw	fixed knife
6				Washer	screw, fixed knife
7	2	3	4 9-93002	Scraper, rotating segment	
8	4	6	8	Hex head screw	scraper
9	4	6	8	Washer	screw, scraper

9. SPARE PARTS LIST



9.3 Hopper, flaps, feed components

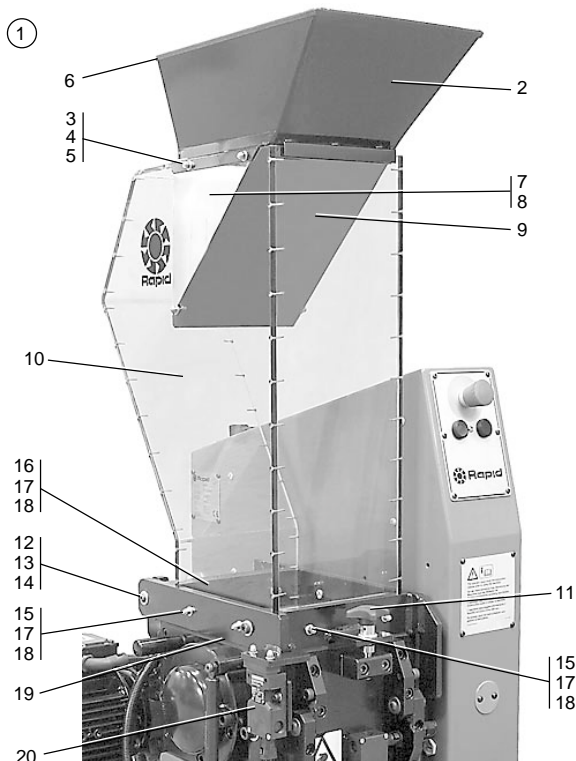

Pos	Qty.	Art. no.	Description
			Granulator 1022
			Granulator 1034
			Granulator 1046
1	1	-	Hopper complete 1022
	-	1	Hopper complete 1034
	-	1	Hopper complete 1046
2	1	-	Hopper funnel 1022
	-	1	Hopper funnel 1034
	-	1	Hopper funnel 1046
3	9	9	Flange screw
4	9	9	Washer
5	9	9	Nut, locking
6	1	1	Protection sealing, hopper funnel
7	1	-	Flap 1022
	-	1	Flap 1034
	-	1	Flap 1046
8	1	-	Holder, flap, hopper 1022
	-	1	Holder, flap, hopper 1034
	-	1	Holder, flap, hopper 1046
9	1	-	Guiding plate 1022
	-	1	Guiding plate 1034
	-	1	Guiding plate 1046
10	1	-	Hopper polycarbonate 1022
	-	1	Hopper polycarbonate 1034
	-	1	Hopper polycarbonate 1046
11	1	1	Star knob
12	2	3	Shaft, hopper
13	4	4	Socket cap screw
14	4	4	Washer
15	6	7	Flange screw
16	2	3	Flange screw
17	8	10	Washer
18	8	10	Nut, locking
19	1	1	Sealing, hopper/cutter housing
20	1	1	Safety switch with mounting kit complete

9.4 Transmission

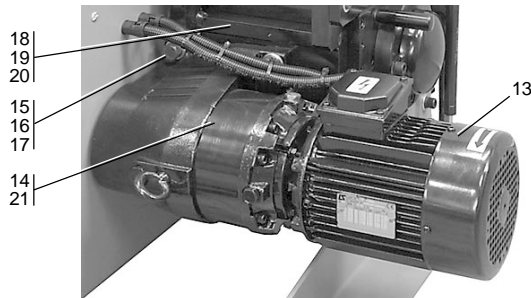
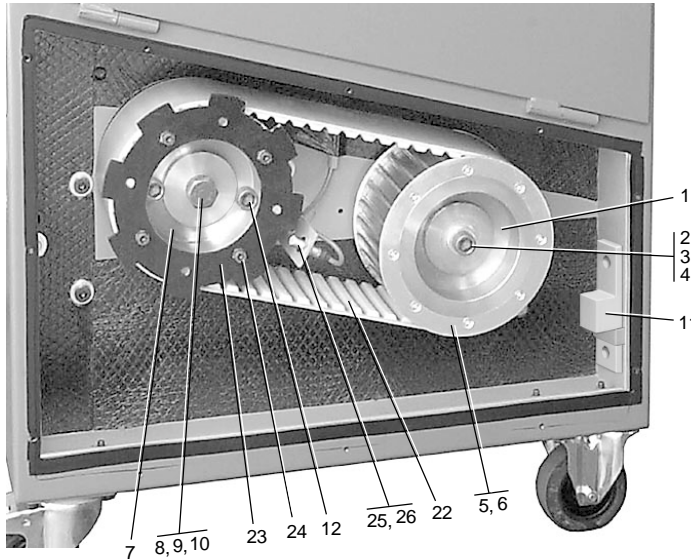

Pos	Qty.					Art. no.	Description
							Granulator 1022
							Granulator 1034
							Granulator 1046
							Granulator 1022 with REV-system
							Granulator 1034 with REV-system
							Granulator 1046 with REV-system
1	1	or	-	1	or	-	Motor pulley 0,75 kW
		or	1	1	or	1	Motor pulley 1,80 kW
2	1	1	1	1	1	1	Socket cap screw
3	1	1	1	1	1	1	Spring washer
4	1	1	1	1	1	1	Washer
5	2	or	-	2	or	-	Support ring, motor pulley 0,75 kW
		or	2	2	or	2	Support ring, motor pulley 1,80 kW
6	16	16	16	16	16	16	Socket cap screw, support ring
7	1	or	-	1	or	-	Cutter pulley 0,75 kW
		or	1	1	or	1	Cutter pulley 1,80 kW
8	1	1	1	1	1	1	Hex head screw
9	1	1	1	1	1	1	Spring washer
10	1	1	1	1	1	1	Washer
11	1	1	1	1	1	1	Remover
12	2	2	2	2	2	2	Socket cap screw
13	1	or	-	1	or	-	9-93003 Motor 0,75 kW
		or	1	1	or	1	9-93004 Motor 1,80 kW
14	1	1	-	1	-	-	Reduction gear 0,75 kW
		or	1	1	or	1	Reduction gear 1,80 kW
15	4	4	4	4	4	4	Hex head screw
16	4	4	4	4	4	4	Spring washer
17	4	4	4	4	4	4	Washer
18	1	or	-	1	or	-	Bracket, reduction gear 0,75 kW
		or	1	1	or	1	Bracket, reduction gear 1,80 kW
19	4	4	4	4	4	4	Socket cap screw
20	4	4	4	4	4	4	Washer
21	-	-	-	-	-	-	Oil, reduction gear 1,0 lit.
22	1	or	-	1	or	-	9-93005 Drive belt 50AT20/1200SYN
		or	1	1	or	1	9-93006 Drive belt 100AT20/1200SYN
23	-	-	-	1	1	1	Indication ring
24	-	-	-	4	4	4	Socket cap screw, indication ring
25	-	-	-	1	1	1	Sensor
26	-	-	-	1	1	1	Relay, REV-system

9. SPARE PARTS LIST

9.5 Granule bin

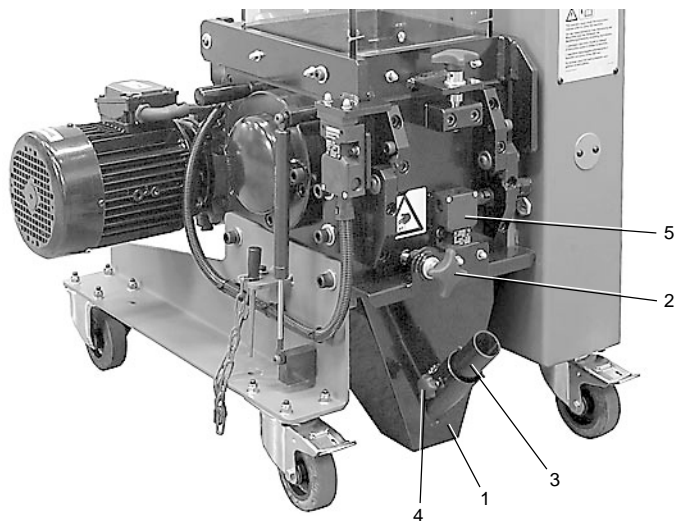

Pos	Qty.	Art. no.	Description
			Granulator 1022
			Granulator 1034
			Granulator 1046
1	1	-	Granule bin 1022
	-	1	Granule bin 1034
	-	1	Granule bin 1046
2	1	1	Star knob, locking granule bin
3	1	1	Suction pipe
4	1	1	Star knob, suction pipe
5	1	1	Safety switch with monting kit, complete

9.6 Stand

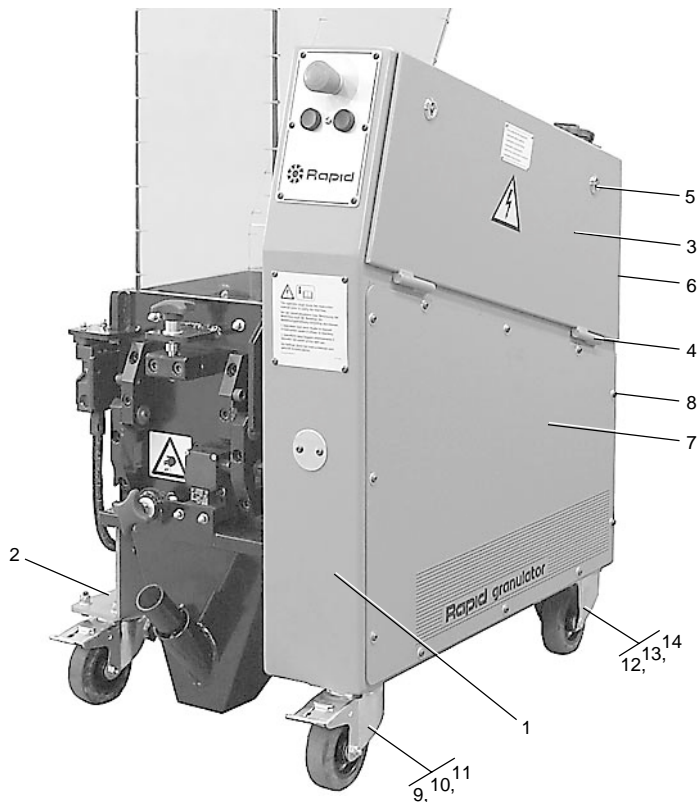

Pos	Qty.	Art. no.	Description
			Granulator 1022
			Granulator 1034
			Granulator 1046
1	1	1	Stand
2	1	1	Support, stand
3	1	1	Door, electrical cabinet
4	2	2	Hinge
5	2	2	Lock, door lock
6	1	1	List, edge protection
7	1	1	Covering plate, transmission
8	11	11	Socket cap screw M5
9	2	2	9-93007 Wheel, turnable with brake
10	8	8	Socket cap screw
11	8	8	Nut, locking
12	2	2	9-93008 Wheel, fixed
13	8	8	Socket cap screw
14	8	8	Nut, locking

9. SPARE PARTS LIST

9.7 Paddle monitor

①

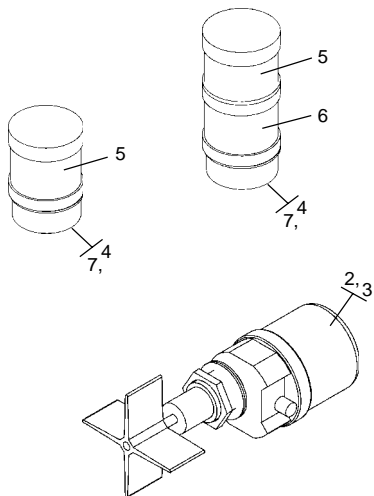

Pos	Qty.	Art. no.	Description
1	<input type="checkbox"/>	<input type="checkbox"/>	3-40477 Paddle monitor with warning lamp 24V
		<input type="checkbox"/>	3-40476 Paddle monitor with warning lamp and siren 24V
2	1	1	911105 Paddle monitor RP-5
3	1	1	911266 Connector 8-pol
4	1	1	911532 Adapter
5	1	1	911523 Warning lamp 24V
6	-	1	911529 Siren
7	2	2	9404084 Socket cap screw M4

10-range

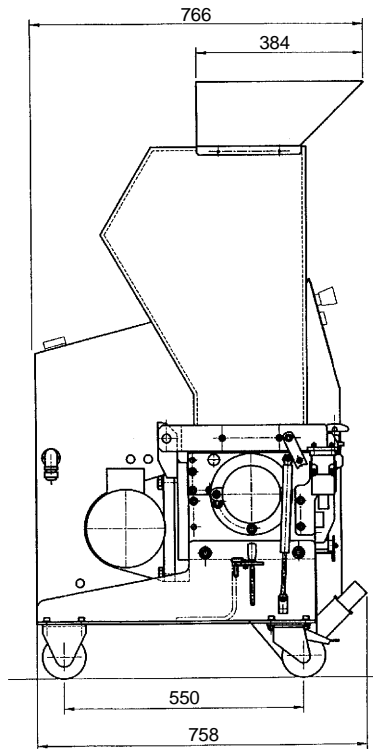
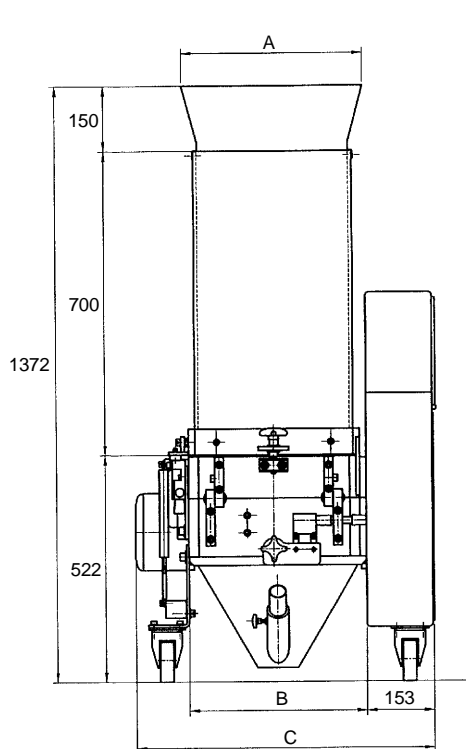

	1022	1034	1046
A	291	412	530
B	284	405	525
C	605	680	773

11.1 General

The machine must be packaged and transported by trained personnel.

All instructions must be observed, to avoid damage.

11.2 Transport

Read through all of chapter 11 before transporting the machine.

Outdoors

If the machine must be transported exposed to the elements, all unpainted components on the machine must be treated with rust preventer.

After this, the machine must be packed in protective plastic film and fixed to a transport pallet with PET straps or tension straps.

Indoors

The machine can be transported short distances on dry, even surfaces on its transport wheels.

Two of the machine's transport wheels can be turned, which facilitates transport.

If the machine has to be transported longer distances, it should be fixed to a transport pallet with PET straps or tension straps. It can then be transported on a fork-lift truck or traversing crane.

Lifting the machine

The machine weighs 335 - 385 kg with packaging.

Space requirements, see Layout, chapter 10.

The machine can be lifted and handled with a fork-lift truck or a traversing crane.

With a fork-lift truck

The machine can be lifted and handled with a fork-lift truck.

1. Set the fork width on fork-lift truck to 400 mm.
2. Remove the granule bin.
3. Drive in the fork-lift truck and make sure that the lifting forks balancing the granulator, then lift the machine.

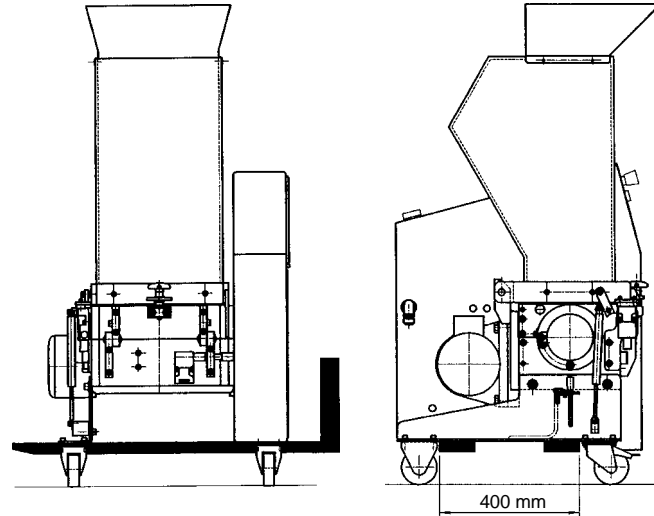

11. TRANSPORT AND STORAGE



With traversing crane and a lifting strop

The machine can be lifted by means of a double strop and a lifting yoke.

The length of the strop should be at least 5 metre (10.0 m circumference).

1. Remove the granule bin.
2. Install the lifting strop underneath the granulator stand.
3. Then install a lifting yoke.

Use a traversing crane or a fork-lift truck and then lift the machine as shown in the illustrations.

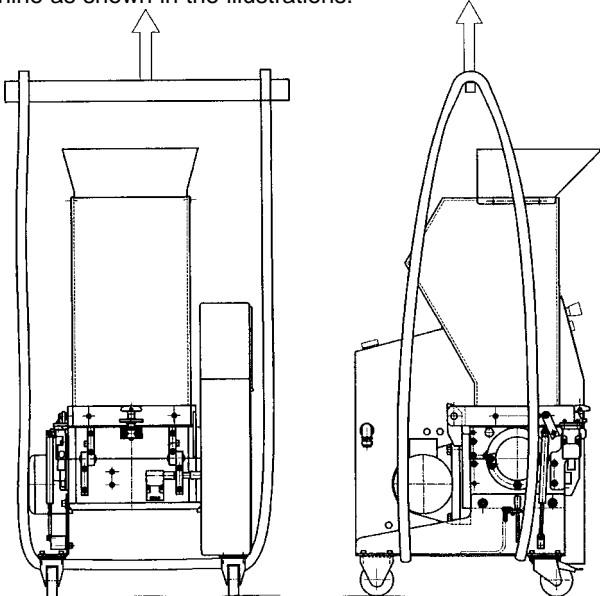

11:2

10-range

11.3 Storage

Long term storage

- Store the machine in dry premises with an even temperature.
- Treat all unpainted surfaces on the machine at once with rust preventer.

Use

Castrol DWX 22 which will protect the machine for up to 12 months.

Or Castrol DWX 160 which will protect the machine for 24 - 36 months.

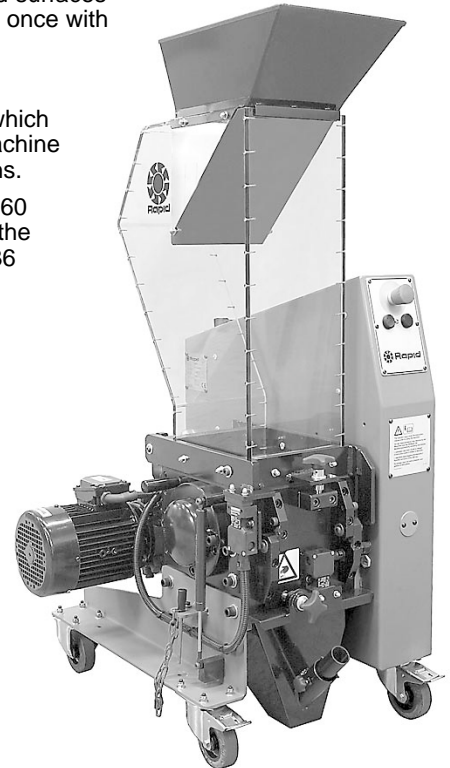

2001-11-02

Cutter housing

Cutter housing opening

1022	241 x 223 mm.
1034	241 x 343 mm.
1046	241 x 464 mm.

Motor

Granulator model	Motor power	Cutter speed
1022	0,75 kW	25 rpm.
- option	1,80 kW	27 rpm.
1034	1,80 kW	27 rpm.
- option	0,75 kW	25 rpm.
1046	1,80 kW	27 rpm.

Cutting parts and fixed knives

Rotating	feed hook Ø 248	segment
1022	1 pcs. 2 pcs.
1034	2 pcs. 3 pcs.
1046	3 pcs. 4 pcs.

Fixed knives

1022	2 pcs.
1034	3 pcs.
1046	4 pcs.

Knife clearance

side rotating segment – fixed knife	0,25 mm.
knifedge rotating segment – fixed knife	0,10 - 0,20 mm.

Tightening torque, fixed knives 85 Nm.

Granule bin

Capacity

1022	7,0 lit.
1034	10,0 lit.
1046	13,0 lit.

Transmission

Drive belt, motor 0,75 and 1,80 kW, ribbed belt . art.no.

Tightening torque, cutter pulley 220 Nm.

Tightening torque, motor pulley 220 Nm.

Tightening torque, reduction gear 220 Nm.

Sound level

1022	approx. 62 dBA.
1034	approx. 62 dBA.
1046	approx. 62 dBA.

Weight

Motor power	0,75 kW	1,80 kW
1022	315 kg.	320 kg.
1034	335 kg.	340 kg.
1046	355 kg.	360 kg.

12. MAINTENANCE AND SERVICE SCHEDULE



Every 6 months or 4000 running hours

Check the wear on fixed knives, rotating segment and feed hook. Check the tightening torque of the fixed knives retaining screws.

..... / 20	Fixed knives	<input type="checkbox"/> OK	<input type="checkbox"/> Grind	<input type="checkbox"/> OK tightening torque / 20	Fixed knives	<input type="checkbox"/> OK	<input type="checkbox"/> Grind	<input type="checkbox"/> OK tightening torque
	Rotating segment	<input type="checkbox"/> OK	<input type="checkbox"/> Grind			Rotating segment	<input type="checkbox"/> OK	<input type="checkbox"/> Grind	
	Rotating feed hook	<input type="checkbox"/> OK	<input type="checkbox"/> Grind	Sign:		Rotating feed hook	<input type="checkbox"/> OK	<input type="checkbox"/> Grind	Sign:
..... / 20	Fixed knives	<input type="checkbox"/> OK	<input type="checkbox"/> Grind	<input type="checkbox"/> OK tightening torque / 20	Fixed knives	<input type="checkbox"/> OK	<input type="checkbox"/> Grind	<input type="checkbox"/> OK tightening torque
	Rotating segment	<input type="checkbox"/> OK	<input type="checkbox"/> Grind			Rotating segment	<input type="checkbox"/> OK	<input type="checkbox"/> Grind	
	Rotating feed hook	<input type="checkbox"/> OK	<input type="checkbox"/> Grind	Sign:		Rotating feed hook	<input type="checkbox"/> OK	<input type="checkbox"/> Grind	Sign:
..... / 20	Fixed knives	<input type="checkbox"/> OK	<input type="checkbox"/> Grind	<input type="checkbox"/> OK tightening torque / 20	Fixed knives	<input type="checkbox"/> OK	<input type="checkbox"/> Grind	<input type="checkbox"/> OK tightening torque
	Rotating segment	<input type="checkbox"/> OK	<input type="checkbox"/> Grind			Rotating segment	<input type="checkbox"/> OK	<input type="checkbox"/> Grind	
	Rotating feed hook	<input type="checkbox"/> OK	<input type="checkbox"/> Grind	Sign:		Rotating feed hook	<input type="checkbox"/> OK	<input type="checkbox"/> Grind	Sign:
..... / 20	Fixed knives	<input type="checkbox"/> OK	<input type="checkbox"/> Grind	<input type="checkbox"/> OK tightening torque / 20	Fixed knives	<input type="checkbox"/> OK	<input type="checkbox"/> Grind	<input type="checkbox"/> OK tightening torque
	Rotating segment	<input type="checkbox"/> OK	<input type="checkbox"/> Grind			Rotating segment	<input type="checkbox"/> OK	<input type="checkbox"/> Grind	
	Rotating feed hook	<input type="checkbox"/> OK	<input type="checkbox"/> Grind	Sign:		Rotating feed hook	<input type="checkbox"/> OK	<input type="checkbox"/> Grind	Sign:
..... / 20	Fixed knives	<input type="checkbox"/> OK	<input type="checkbox"/> Grind	<input type="checkbox"/> OK tightening torque / 20	Fixed knives	<input type="checkbox"/> OK	<input type="checkbox"/> Grind	<input type="checkbox"/> OK tightening torque
	Rotating segment	<input type="checkbox"/> OK	<input type="checkbox"/> Grind			Rotating segment	<input type="checkbox"/> OK	<input type="checkbox"/> Grind	
	Rotating feed hook	<input type="checkbox"/> OK	<input type="checkbox"/> Grind	Sign:		Rotating feed hook	<input type="checkbox"/> OK	<input type="checkbox"/> Grind	Sign:
..... / 20	Fixed knives	<input type="checkbox"/> OK	<input type="checkbox"/> Grind	<input type="checkbox"/> OK tightening torque / 20	Fixed knives	<input type="checkbox"/> OK	<input type="checkbox"/> Grind	<input type="checkbox"/> OK tightening torque
	Rotating segment	<input type="checkbox"/> OK	<input type="checkbox"/> Grind			Rotating segment	<input type="checkbox"/> OK	<input type="checkbox"/> Grind	
	Rotating feed hook	<input type="checkbox"/> OK	<input type="checkbox"/> Grind	Sign:		Rotating feed hook	<input type="checkbox"/> OK	<input type="checkbox"/> Grind	Sign:
..... / 20	Fixed knives	<input type="checkbox"/> OK	<input type="checkbox"/> Grind	<input type="checkbox"/> OK tightening torque / 20	Fixed knives	<input type="checkbox"/> OK	<input type="checkbox"/> Grind	<input type="checkbox"/> OK tightening torque
	Rotating segment	<input type="checkbox"/> OK	<input type="checkbox"/> Grind			Rotating segment	<input type="checkbox"/> OK	<input type="checkbox"/> Grind	
	Rotating feed hook	<input type="checkbox"/> OK	<input type="checkbox"/> Grind	Sign:		Rotating feed hook	<input type="checkbox"/> OK	<input type="checkbox"/> Grind	Sign:
..... / 20	Fixed knives	<input type="checkbox"/> OK	<input type="checkbox"/> Grind	<input type="checkbox"/> OK tightening torque / 20	Fixed knives	<input type="checkbox"/> OK	<input type="checkbox"/> Grind	<input type="checkbox"/> OK tightening torque
	Rotating segment	<input type="checkbox"/> OK	<input type="checkbox"/> Grind			Rotating segment	<input type="checkbox"/> OK	<input type="checkbox"/> Grind	
	Rotating feed hook	<input type="checkbox"/> OK	<input type="checkbox"/> Grind	Sign:		Rotating feed hook	<input type="checkbox"/> OK	<input type="checkbox"/> Grind	Sign:
..... / 20	Fixed knives	<input type="checkbox"/> OK	<input type="checkbox"/> Grind	<input type="checkbox"/> OK tightening torque / 20	Fixed knives	<input type="checkbox"/> OK	<input type="checkbox"/> Grind	<input type="checkbox"/> OK tightening torque
	Rotating segment	<input type="checkbox"/> OK	<input type="checkbox"/> Grind			Rotating segment	<input type="checkbox"/> OK	<input type="checkbox"/> Grind	
	Rotating feed hook	<input type="checkbox"/> OK	<input type="checkbox"/> Grind	Sign:		Rotating feed hook	<input type="checkbox"/> OK	<input type="checkbox"/> Grind	Sign:
..... / 20	Fixed knives	<input type="checkbox"/> OK	<input type="checkbox"/> Grind	<input type="checkbox"/> OK tightening torque / 20	Fixed knives	<input type="checkbox"/> OK	<input type="checkbox"/> Grind	<input type="checkbox"/> OK tightening torque
	Rotating segment	<input type="checkbox"/> OK	<input type="checkbox"/> Grind			Rotating segment	<input type="checkbox"/> OK	<input type="checkbox"/> Grind	
	Rotating feed hook	<input type="checkbox"/> OK	<input type="checkbox"/> Grind	Sign:		Rotating feed hook	<input type="checkbox"/> OK	<input type="checkbox"/> Grind	Sign:

Check annually or 8000 running hours

Check the drive belt condition, oil level in reduction gear and sealings to cutter house bearings.

..... / 20	Drive belt	<input type="checkbox"/> OK	<input type="checkbox"/> Replaced	
	Reduction gear, oil level	<input type="checkbox"/> OK	<input type="checkbox"/> Adjusted	
	Sealings cutter house bearings	<input type="checkbox"/> OK	<input type="checkbox"/> Replaced	Sign:
..... / 20	Drive belt	<input type="checkbox"/> OK	<input type="checkbox"/> Replaced	
	Reduction gear, oil level	<input type="checkbox"/> OK	<input type="checkbox"/> Adjusted	
	Sealings cutter house bearings	<input type="checkbox"/> OK	<input type="checkbox"/> Replaced	Sign:
..... / 20	Drive belt	<input type="checkbox"/> OK	<input type="checkbox"/> Replaced	
	Reduction gear, oil level	<input type="checkbox"/> OK	<input type="checkbox"/> Adjusted	
	Sealings cutter house bearings	<input type="checkbox"/> OK	<input type="checkbox"/> Replaced	Sign:
..... / 20	Drive belt	<input type="checkbox"/> OK	<input type="checkbox"/> Replaced	
	Reduction gear, oil level	<input type="checkbox"/> OK	<input type="checkbox"/> Adjusted	
	Sealings cutter house bearings	<input type="checkbox"/> OK	<input type="checkbox"/> Replaced	Sign:
..... / 20	Drive belt	<input type="checkbox"/> OK	<input type="checkbox"/> Replaced	
	Reduction gear, oil level	<input type="checkbox"/> OK	<input type="checkbox"/> Adjusted	
	Sealings cutter house bearings	<input type="checkbox"/> OK	<input type="checkbox"/> Replaced	Sign:
..... / 20	Drive belt	<input type="checkbox"/> OK	<input type="checkbox"/> Replaced	
	Reduction gear, oil level	<input type="checkbox"/> OK	<input type="checkbox"/> Adjusted	
	Sealings cutter house bearings	<input type="checkbox"/> OK	<input type="checkbox"/> Replaced	Sign:
..... / 20	Drive belt	<input type="checkbox"/> OK	<input type="checkbox"/> Replaced	
	Reduction gear, oil level	<input type="checkbox"/> OK	<input type="checkbox"/> Adjusted	
	Sealings cutter house bearings	<input type="checkbox"/> OK	<input type="checkbox"/> Replaced	Sign:
..... / 20	Drive belt	<input type="checkbox"/> OK	<input type="checkbox"/> Replaced	
	Reduction gear, oil level	<input type="checkbox"/> OK	<input type="checkbox"/> Adjusted	
	Sealings cutter house bearings	<input type="checkbox"/> OK	<input type="checkbox"/> Replaced	Sign:

Changing of cutting parts

..... / 20	<input type="checkbox"/> Rotating segment	<input type="checkbox"/> Rotating feed hook	
	<input type="checkbox"/> Fixed knives	Note:	Sign:
..... / 20	<input type="checkbox"/> Rotating segment	<input type="checkbox"/> Rotating feed hook	
	<input type="checkbox"/> Fixed knives	Note:	Sign:
..... / 20	<input type="checkbox"/> Rotating segment	<input type="checkbox"/> Rotating feed hook	
	<input type="checkbox"/> Fixed knives	Note:	Sign:
..... / 20	<input type="checkbox"/> Rotating segment	<input type="checkbox"/> Rotating feed hook	
	<input type="checkbox"/> Fixed knives	Note:	Sign:
..... / 20	<input type="checkbox"/> Rotating segment	<input type="checkbox"/> Rotating feed hook	
	<input type="checkbox"/> Fixed knives	Note:	Sign:
..... / 20	<input type="checkbox"/> Rotating segment	<input type="checkbox"/> Rotating feed hook	
	<input type="checkbox"/> Fixed knives	Note:	Sign:
..... / 20	<input type="checkbox"/> Rotating segment	<input type="checkbox"/> Rotating feed hook	
	<input type="checkbox"/> Fixed knives	Note:	Sign:
..... / 20	<input type="checkbox"/> Rotating segment	<input type="checkbox"/> Rotating feed hook	
	<input type="checkbox"/> Fixed knives	Note:	Sign:
..... / 20	<input type="checkbox"/> Rotating segment	<input type="checkbox"/> Rotating feed hook	
	<input type="checkbox"/> Fixed knives	Note:	Sign:
..... / 20	<input type="checkbox"/> Rotating segment	<input type="checkbox"/> Rotating feed hook	
	<input type="checkbox"/> Fixed knives	Note:	Sign:
..... / 20	<input type="checkbox"/> Rotating segment	<input type="checkbox"/> Rotating feed hook	
	<input type="checkbox"/> Fixed knives	Note:	Sign:
..... / 20	<input type="checkbox"/> Rotating segment	<input type="checkbox"/> Rotating feed hook	
	<input type="checkbox"/> Fixed knives	Note:	Sign:
..... / 20	<input type="checkbox"/> Rotating segment	<input type="checkbox"/> Rotating feed hook	
	<input type="checkbox"/> Fixed knives	Note:	Sign:

12. MAINTENANCE AND SERVICE SCHEDULE



Malfunctions

..... / 20 Fault:
Action:
..... Sign:

..... / 20 Fault:
Action:
..... Sign:

..... / 20 Fault:
Action:
..... Sign:

..... / 20 Fault:
Action:
..... Sign:

..... / 20 Fault:
Action:
..... Sign:

..... / 20 Fault:
Action:
..... Sign:

..... / 20 Fault:
Action:
..... Sign:

..... / 20 Fault:
Action:
..... Sign:

..... / 20 Fault:
Action:
..... Sign:

..... / 20 Fault:
Action:
..... Sign:

..... / 20 Fault:
Action:
..... Sign:

..... / 20 Fault:
Action:
..... Sign:

..... / 20 Fault:
Action:
..... Sign:

..... / 20 Fault:
Action:
..... Sign:

..... / 20 Fault:
Action:
..... Sign:

Notes

..... / 20 Notes:
Action:
..... Sign:

..... / 20 Notes:
Action:
..... Sign:

..... / 20 Notes:
Action:
..... Sign:

..... / 20 Notes:
Action:
..... Sign:

..... / 20 Notes:
Action:
..... Sign:

..... / 20 Notes:
Action:
..... Sign:

..... / 20 Notes:
Action:
..... Sign:

..... / 20 Notes:
Action:
..... Sign:

..... / 20 Notes:
Action:
..... Sign:

..... / 20 Notes:
Action:
..... Sign:

..... / 20 Notes:
Action:
..... Sign:

..... / 20 Notes:
Action:
..... Sign:

..... / 20 Notes:
Action:
..... Sign:

..... / 20 Notes:
Action:
..... Sign:

..... / 20 Notes:
Action:
..... Sign: